

**IMFLDP Call for Sites
Tulloch Homes Ltd and Associated Companies
Schedule of Sites**

Site	Location	Indicative No of Units	Comments
1. Schoolhouse Belt	Cononbridge	28	08/00140/FULRC
2. Braes of Conon	Cononbridge	209	08/00994/FULRC
3. Wester Inshes Ph3	Inverness	109	07/00494/FULIN
4. Cradlehall Ph3	Inverness	3	06/00494/FULIN
5. Hedgefield House	Inverness	39	07/00302/FULIN 38 residential + 1 business
6. Culduthel Ph9	Inverness	27	15 additional units
7. North Kessock Ph3a – 6	North Kessock	129	07/00876/REMRC
8. Fortrose Ph B-G	Fortrose		09/00471/OUTRC 09/00472/FULRC
9. Parks Farm Ph1-6	Inverness	341	10/03124/FUL
10. Balintore	Balintore	19	05/00844/OUTRC 06/00866/FULRC
11. Broomhill	Muir of Ord	120	30 affordable built out 07/01019/REMRC
12. Tulloch Square	Dingwall	28	

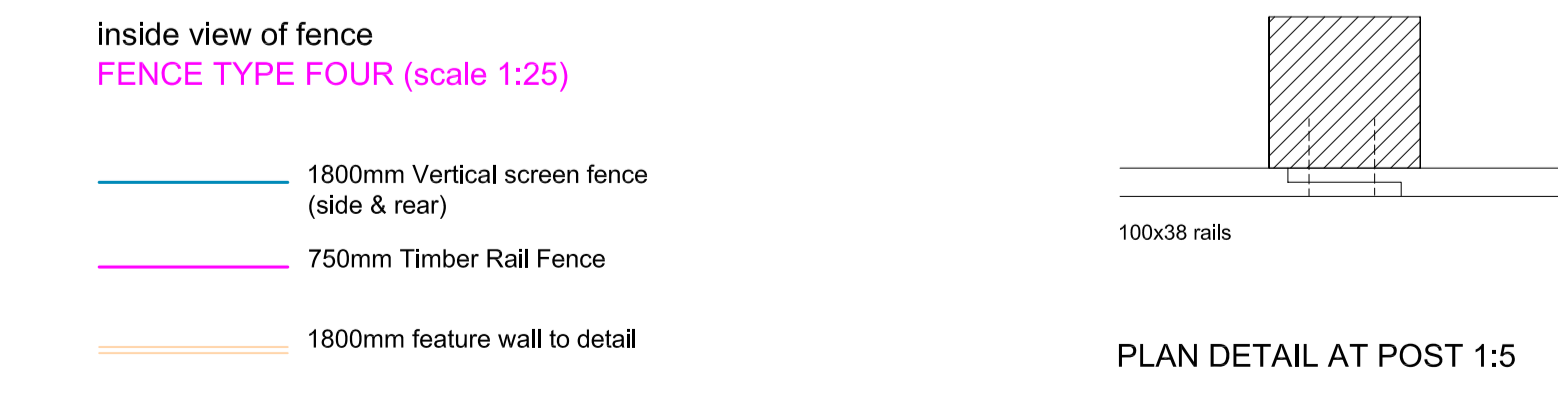
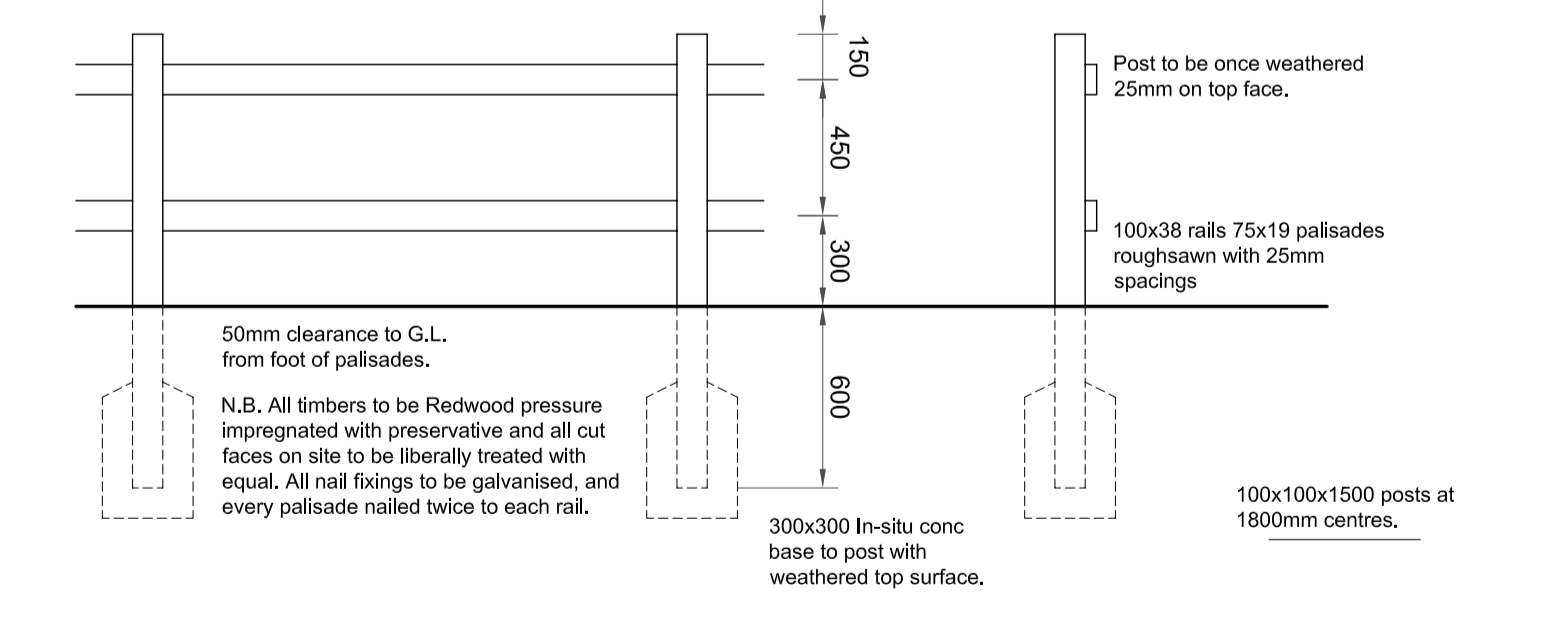
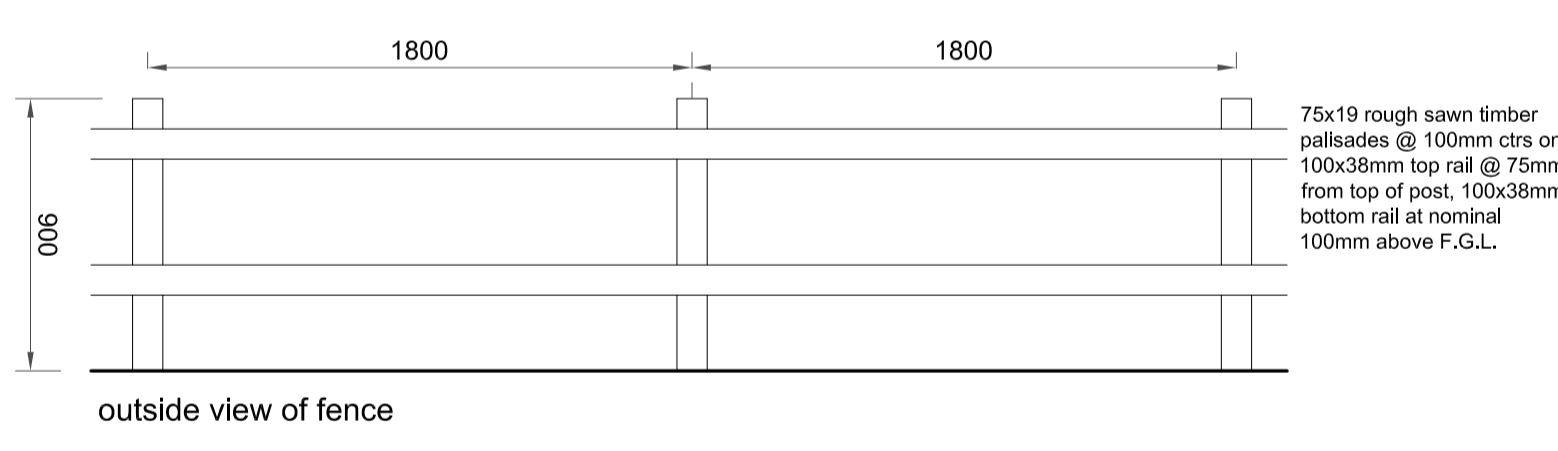
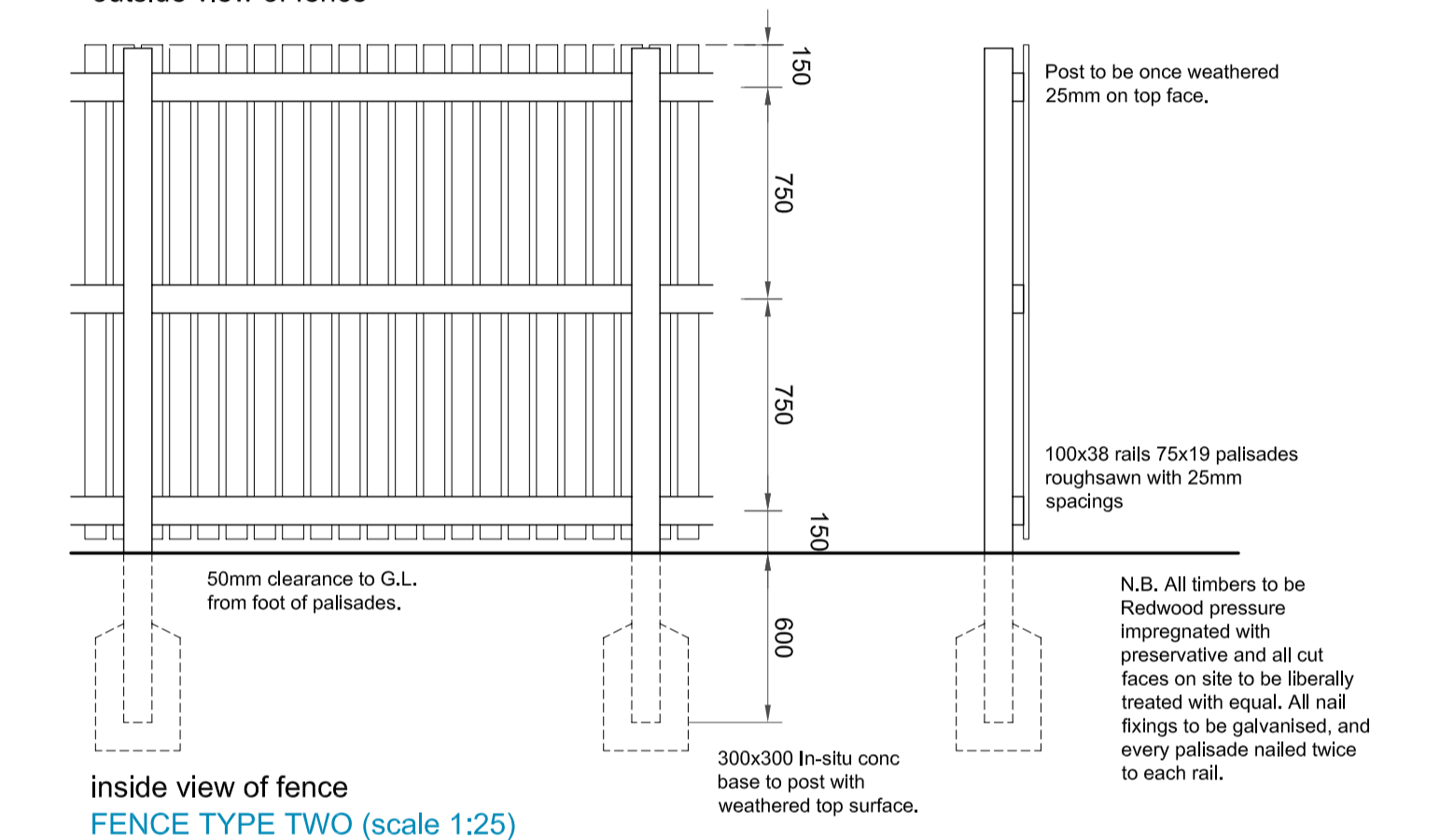
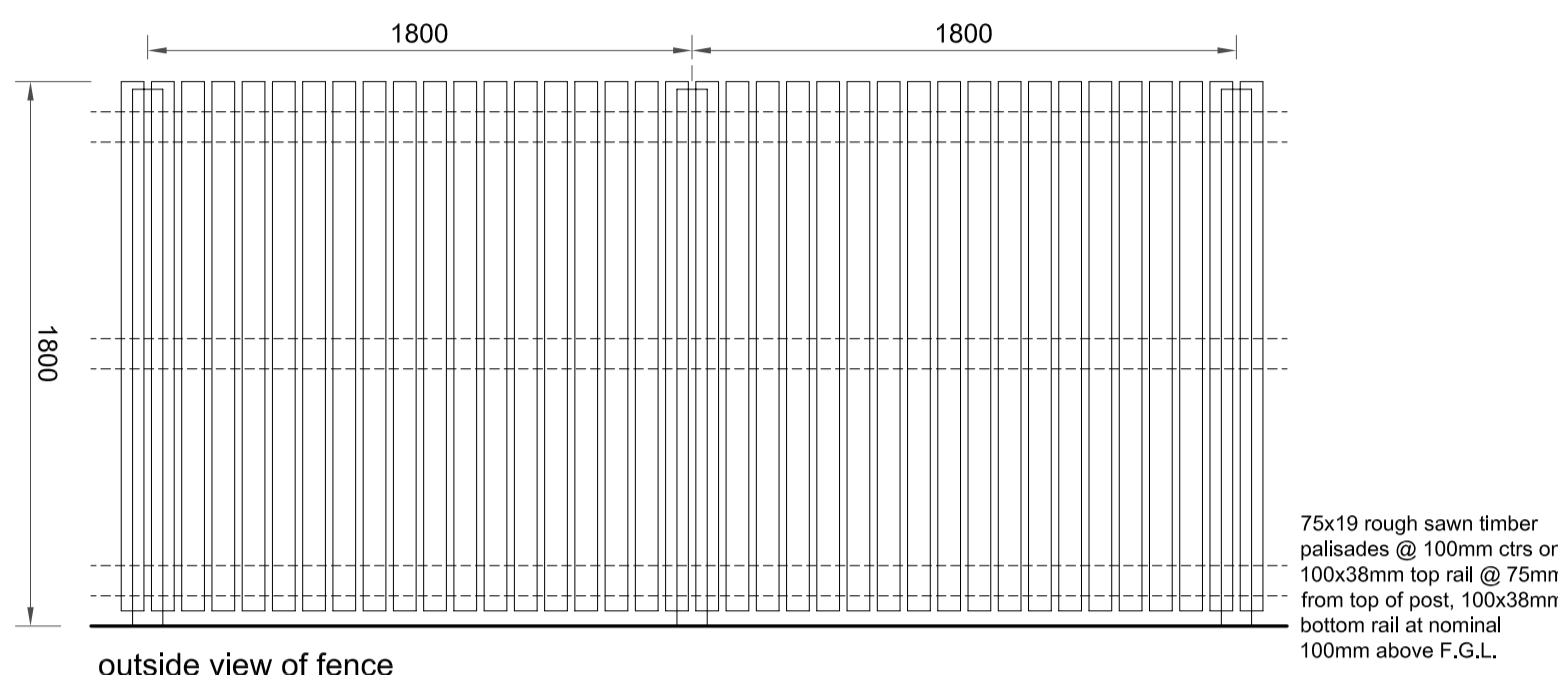
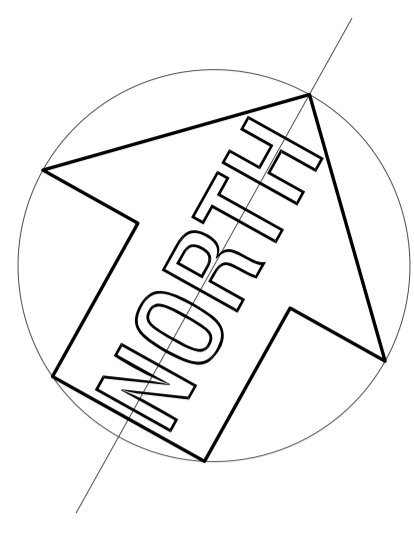

REV H	TURNING HEAD UPDATED IN LINE WITH ROADS DEPARTMENT'S COMMENTS	JUNE 07
REV G	PLAY AREA POSITION AGREED	JUNE 07
REV F	UPDATED FOLLOWING APRILS DESIGN TEAM MEETING	APRIL 07
REV E	ROAD UPDATED IN LINE WITH ENGINEERS	MARH 07
REV D	TURNING HEAD UPDATED	14 FEB 07
REV C	FLOOR LEVELS & DRAINAGE UPDATED	30 JAN 07
REV B	TURNING HEAD UPDATED	19 JAN 07
REV A	AFFORDABLE HOUSING REPOSITIONED	JAN 07

Bracewell Stirling Architects
 ● 38 WALKER TERRACE, TILlicOULTRY, FK13 6EF TEL: 01259 750301 FAX: 01259 752365
 ○ 5 NESS BANK, INVERNESS, IV2 4SF TEL: 01463 233760 FAX: 01463 233785

BALINTORE ESTATE, BALINTORE AVIEMORE & HIGHLAND DEVELOPMENTS
SITE LAYOUT
 SCALE 1:500 DATE SEP 06 BY SM
 DWG NO 3021 - 50 REV H