

**THE HIGHLAND COUNCIL**

**SOUTH PLANNING APPLICATIONS COMMITTEE**  
**27 September 2016**

Agenda Item	5.3
Report No	PLS 054/16

**16/02464/FUL: Scottish Water**  
**Ardersier Waste Water Treatment Works, Ardersier**

**Report by Area Planning Manager – South / Major Developments**

**SUMMARY**

**Description:** Installation of Ultraviolet Treatment Plant at the Ardersier Waste Water Treatment Works

**Recommendation : GRANT**

**Ward:** 18 - Culloden and Ardersier

**Development category:** Local Development

**Pre-determination hearing:** None.

**Reason referred to Committee:** Objection from Community Council and 5 or more objections

**1. PROPOSED DEVELOPMENT**

- 1.1 This application relates to the provision of an ultra violet treatment plant (UVTP) to be located adjacent to the existing Ardersier Waste Water Treatment Works (WWTW). The application also includes the provision of a new access into the WWTW to replace the existing access and the extension of fencing around the perimeter of the site to accommodate the extension. The purpose of the UV Disinfection Plant is to improve the water quality of the final effluent, which Scottish Water has stated, will be of bathing water standard once the UV plant is installed.
- 1.2 The UVTP will give an additional level of treatment to the waste being processed at the Ardersier WWTW before it is discharged via the existing outfall into the Outer Moray Firth. The plant is mainly sited below ground, is some 4.6 metres long and of a height of 2.8 metres. It will be sited within the existing WWTW works, located to the rear of the existing equipment.
- 1.3 The site has historically been accessed via the B9006. This application seeks to provide a new access to the site which will be located to the south of the existing access and closer to the existing equipment. The existing site access will remain but the proposed new access will become the main access serving the existing

WWTP.

1.4 The application includes a supporting statement to address matters raised by the Planning Authority. This included information on the requirements for the works, planning policy, access and traffic management and assesses impacts on the historic environment.

1.5 **Variations:** None.

## **2. SITE DESCRIPTION**

2.1 The site lies to the north and west of the existing WWTW between the existing access into the site and the works themselves. Ardersier is located approximately 500m to the south east and Fort George is located 1km to the north west. The site is currently screened by low level vegetation. The site is served by the B9006 public road and the Inner Moray Firth is located to the west adjacent to which a public footpath connects the village of Ardersier to Fort George.

2.2 There are no natural or cultural heritage designations covering the site but the Moray Firth is a designated Special Area of Conservation and the area to the east of the B9006 is a designated SSSI.

## **3. PLANNING HISTORY**

3.1 24.01.2011 – planning permission granted for construction of new WWTP and associated works (10/02007/FUL).

## **4. PUBLIC PARTICIPATION**

4.1 Advertised : Schedule 3 development & Unknown Neighbour

Representation deadline : 22 July 2016

Timeous representations : 19 representations

Late representations : 0

4.2 Material considerations raised are summarised as follows:

- In principle objection (2)
- Traffic Impact (10)
- Impact on wildlife (7);
- Construction Impacts;
- Flood Risk
- Impact on business / Tourism in Ardersier(5)

4.3 Non-material issues raised are summarised as follows:

- Odour in Ardersier (7);

- Impact on air quality(2);
- Impact on health;
- Scale of WWTW development (mass and capacity);
- Not proper planning of the area an alternative site for the WWTW should be considered(4)
- Impact on heritage in Ardersier (7)

4.4 All letters of representation are available for inspection via the Council's eplanning portal which can be accessed through the internet [www.wam.highland.gov.uk/wam](http://www.wam.highland.gov.uk/wam). Access to computers can be made available via Planning and Development Service offices.

## 5. CONSULTATIONS

5.1 **Transport Planning** has no objection on the basis that there will be little additional traffic movements as a result of the development.

The applicant has confirmed that during construction, there will be a requirement for delivery vehicles (HGV's) but these will be restricted for a limited period involving delivery of the UV plant and during road construction. It is anticipated that up to 4 HGV's would be involved during the initial construction period and thereafter reduced to 1 or 2 daily deliveries. The construction period will extend over 5 months but with the main HGV activity during the first month on site.

On the basis of this information, Transport Planning do not object to the proposal given that the B9006 does not have any restrictions for HGV usage. Conditions are sought to secure a traffic management plan, construction details of the new access, visibility splays and proposed use of the existing access to the site.

5.2 **THC Access Officer:** No objection to the application. An informative is requested related to the core paths adjacent to the site.

5.3 **THC Environmental Health:** No objection to the application.

5.4 **Ardersier and Petty Community Council:** Object to the application. Concerns are raised regarding the timing of this application given that there remain unresolved traffic management issues relating to the intended expansion of the WWTP previously granted consent. It is considered no further development should proceed until these issues are resolved. No specific concerns are raised regarding the proposed new access.

5.5 **Scottish Environment Protection Agency:** No objection to the proposal. The proposals are compliant with the current Controlled Activities Regulations Authorisation for the site.

5.6 **Scottish Natural Heritage:** no objection to the application. It is confirmed that the development can be progressed without significant adverse impacts on the natural heritage and that the discharge from the plant is regulated by SEPA.

## **6. DEVELOPMENT PLAN POLICY**

The following policies are relevant to the assessment of the application:

### **6.1 Highland Wide Local Development Plan 2012**

Policy 9	A96 Corridor - Phasing and Infrastructure
Policy 28	Sustainable Design
Policy 30	Physical Constraints
Policy 57	Natural, Built and Cultural Heritage
Policy 58	Protected Species
Policy 63	Water Environment
Policy 66	Surface Water Drainage

### **6.2 Inner Moray Firth Local Development Plan 2015**

No relevant policies.

### **6.3 Inverness Local Plan (Adopted 2006, As Continued in Force 2012)**

The provisions of the Inverness Local Plan have been superseded in relation to this application by the adoption of the Inner Moray Firth Local Plan.

### **6.4 Highland Council Supplementary Guidance**

The following Supplementary Guidance forms a statutory part of the development plan and is considered relevant to the determination of this application.

- Physical Constraints Supplementary Guidance (March 2013)
- Statutorily Protected Species (March 2013)

## **7. OTHER MATERIAL CONSIDERATIONS**

### **7.1 Scottish Government Planning Policy and Guidance**

National Planning Framework 2  
Scottish Planning Policy  
PAN 51 – Planning, Environmental Protection and Regulation  
PAN 61 – Planning and Sustainable Urban Drainage Systems

## **8. PLANNING APPRAISAL**

8.1 Section 25 of the Town and Country Planning (Scotland) Act 1997 requires planning applications to be determined in accordance with the development plan unless material considerations indicate otherwise.

8.2 This means that the application requires to be assessed against all policies of the Development Plan relevant to the application, all national and local policy guidance and all other material considerations relevant to the application.

### 8.3 **Development Plan Policy Assessment**

Development plan policy is set out in the Highland-wide Local Development Plan and the Inner Moray Firth Local Development Plan. The site is not within a land allocation.

The treatment process currently consists of primary screening and settlement followed by secondary activated sludge assisted degradation. Bacteriological control of the final effluent is to be achieved through this proposal by tertiary disinfection by ultraviolet irradiation. This will improve existing facilities and is not directly related to the existing planning permission for the construction of a new WWTP at the site. Scottish Water, as a statutory undertaker, currently benefits from certain 'permitted development' rights. The associated underground works fall under this category and do not require planning permission. The principle of the development is therefore supported by policy and will result in an improved water quality effluent. The installation of the UV plant does not pre-empt in any way the development associated with the alterations and expansion of the existing facilities as set out in the extant planning permission but rather seeks only to improve discharge to the outer Moray Firth. This upgrade is above the specifications required by SEPA but is nevertheless welcome.

The proposed new access road is to be located within the boundary of the existing works and will provide a dedicated access for the WWTP. Transport Planning has identified that the design of the access junction with the B9006 can be constructed in accordance with requisite standards and appropriate visibility splays provided. The existing shared access will not be altered but will no longer be required by Scottish Water.

### 8.4 **Material Considerations**

The consultees have each identified that there are no objections to the proposed UV plant or new access. Conditions will be required to address traffic management issues and details of the proposed new access. This will require a Construction Traffic Management Plan. The UV plant is not specifically required by the relevant regulatory consultees but will nevertheless result in an improved final discharge into the Firth and is therefore welcomed. The new access will replace the existing access and it is understood will now be used to service the existing WWTP. The existing access will be retained but no longer required by Scottish Water when accessing their site.

Concerns raised by third parties are noted. The Community Council is concerned that further development should proceed on site ahead of resolving the suspensive conditions associated with the extant planning permission for expansion of the WWTP. Whilst their concerns are appreciated, this development does not pre-empt the process involved in discharge of the conditions related to that permission and will require a specific traffic management regime to address the transport issues associated with this development. As a closed facility, there will be no opportunity for emission of odours and the plant itself is no higher than existing buildings within the plant area.

Construction traffic will be required during the installation of the plant but the main activity will extend over only one month. It is intended to include conditions both requiring a traffic management plan for this development and to take account of, for example, key traffic times within the village such as the school bus services. Should development commence on the extant permission for the development of the extended WWTP, the traffic management plan associated with that development will require to take into account the installation of the UV plant thereby ensuring that traffic matters are properly addressed.

#### 8.5 **Other Considerations – not material**

Other matters raised by third parties are noted but are not material to this particular application. The scale of the plant proposed together with its purpose in improving final discharge will not have an adverse impact on the environment or village of Ardersier. The UV plant is intended to improve the existing facilities and is situated close to the main WWTP with the result that it will not have any visual impact.

#### 8.6 **Matters to be secured by Section 75 Agreement**

None.

### 9. **CONCLUSION**

9.1 All relevant matters have been taken into account when appraising this application. It is considered that the proposal accords with the principles and policies contained within the Development Plan and is acceptable in terms of all other applicable material considerations.

### 10. **RECOMMENDATION**

<b>Action required before decision issued</b>	No
Notification to Scottish Ministers	N
Notification to Historic Scotland	N
Conclusion of Section 75 Agreement	N
Revocation of previous permission	N

**Subject to the above**, it is recommended the application be **Granted** subject to the following conditions and reasons / notes to applicant.:

1. No development shall commence on site until details of how the proposed access arrangements are implemented and submitted to and agreed in writing by the planning authority and thereafter so implemented in accordance with the approved details.

For the avoidance of doubt, following completion of the new access no access may be taken to the Waste Water Treatment Works via the pre-existing access.

**Reason** : in the interest of public safety.

2. No development shall commence on site until a construction phase Traffic Management Plan (including a routing plan for construction vehicles) has been submitted to, and approved in writing by, the Planning Authority. The approved traffic management plan shall be implemented prior to development commencing and remain in place until the development is complete.

**Reason** : in the interests of public safety and ensuring traffic management during construction.

3. No development shall commence until details of a scheme of hard and soft landscaping works have been submitted to, and approved in writing by, the Planning Authority. Details of the scheme shall include:
  - i. All earthworks and existing and finished ground levels in relation to an identified fixed datum point;
  - ii. A plan showing existing landscaping features and vegetation to be retained;
  - iii. The location, design and including materials, of any existing or proposed walls, fences and gates;
  - iv. All soft landscaping and planting works, including plans and schedules showing the location, species and size of each individual tree and/or shrub and planting densities. For the avoidance of doubt this shall include details of additional planting on the eastern boundary; and
  - v. A programme for preparation, completion and subsequent on-going maintenance and protection of all landscaping works.

Landscaping works shall be carried out in accordance with the approved scheme. All planting, seeding or turfing as may be comprised in the approved details shall be carried out in the first planting and seeding seasons following the commencement of development, unless otherwise stated in the approved scheme.

Any trees or plants which within a period of five years from the completion of the development die, for whatever reason are removed or damaged shall be replaced in the next planting season with others of the same size and species.

**Reason:** In order to ensure that a high standard of landscaping is achieved, appropriate to the location of the site.

4. No development shall commence on site until an operational phase Traffic Management Plan (including a routing plan for all delivery and maintenance vehicles) has been submitted to, and approved in writing by, the Planning Authority. The approved operational traffic management plan shall be implemented

prior to the hereby permitted development coming into use and remain in place in perpetuity, unless otherwise agreed in writing by the Planning Authority.

**Reason:** In the interests of road safety.

## **REASON FOR DECISION**

The proposals accord with the provisions of the Development Plan and there are no material considerations which would warrant refusal of the application.

## **TIME LIMITS**

In accordance with Section 58 of the Town and Country Planning (Scotland) Act 1997 (as amended), the development to which this planning permission relates must commence within THREE YEARS of the date of this decision notice. If development has not commenced within this period, then this planning permission shall lapse.

## **FOOTNOTE TO APPLICANT**

### **Initiation and Completion Notices**

The Town and Country Planning (Scotland) Act 1997 (as amended) requires all developers to submit notices to the Planning Authority prior to, and upon completion of, development. These are in addition to any other similar requirements (such as Building Warrant completion notices) and failure to comply represents a breach of planning control and may result in formal enforcement action.

1. The developer must submit a Notice of Initiation of Development in accordance with Section 27A of the Act to the Planning Authority prior to work commencing on site.
2. On completion of the development, the developer must submit a Notice of Completion in accordance with Section 27B of the Act to the Planning Authority.

Copies of the notices referred to are attached to this decision notice for your convenience.

### **Accordance with Approved Plans & Conditions**

You are advised that development must progress in accordance with the plans approved under, and any conditions attached to, this permission. You must not deviate from this permission without consent from the Planning Authority (irrespective of any changes that may separately be requested at the Building Warrant stage or by any other Statutory Authority). Any pre-conditions (those requiring certain works, submissions etc. prior to commencement of development) must be fulfilled prior to work starting on site. Failure to adhere to this permission and meet the requirements of all conditions may invalidate your permission or



result in formal enforcement action

### **Flood Risk**

It is important to note that the granting of planning permission does not imply there is an unconditional absence of flood risk relating to (or emanating from) the application site. As per Scottish Planning Policy (p.198), planning permission does not remove the liability position of developers or owners in relation to flood risk.

### **Local Roads Authority Consent**

In addition to planning permission, you may require one or more separate consents (such as dropped kerb consent, a road openings permit, occupation of the road permit etc.) from TECS Roads prior to work commencing. These consents may require additional work and/or introduce additional specifications and you are therefore advised to contact your local TECS Roads office for further guidance at the earliest opportunity.

Failure to comply with access, parking and drainage infrastructure requirements may endanger road users, affect the safety and free-flow of traffic and is likely to result in enforcement action being taken against you under both the Town and Country Planning (Scotland) Act 1997 and the Roads (Scotland) Act 1984.

Further information on the Council's roads standards can be found at:

<http://www.highland.gov.uk/yourenvironment/roadsandtransport>

Application forms and guidance notes for access-related consents can be downloaded from:

<http://www.highland.gov.uk/yourenvironment/roadsandtransport/roads/Applicationformsforroadoccupation.htm>

### **Mud & Debris on Road**

Please note that it is an offence under Section 95 of the Roads (Scotland) Act 1984 to allow mud or any other material to be deposited, and thereafter remain, on a public road from any vehicle or development site. You must, therefore, put in place a strategy for dealing with any material deposited on the public road network and maintain this until development is complete.

### **Construction Hours & Noise-Generating Activities**

You are advised that construction work associated with the approved development (incl. the loading/unloading of delivery vehicles, plant or other machinery), for which noise is audible at the boundary of the application site, should not normally take place outwith the hours of 08:00 and 19:00 Monday to Friday, 08:00 and 13:00 on Saturdays or at any time on a Sunday or Bank Holiday in Scotland, as prescribed in Schedule 1 of the Banking and Financial Dealings Act 1971 (as amended).

Work falling outwith these hours which gives rise to amenity concerns, or noise at any time which exceeds acceptable levels, may result in the service of a notice under Section 60 of the Control of Pollution Act 1974 (as amended). Breaching a Section 60 notice constitutes an offence and is likely to result in court action.

If you wish formal consent to work at specific times or on specific days, you may apply to the Council's Environmental Health Officer under Section 61 of the 1974 Act. Any such application should be submitted after you have obtained your Building Warrant, if required, and will be considered on its merits. Any decision taken will reflect the nature of the development, the site's location and the proximity of noise sensitive premises. Please contact [env.health@highland.gov.uk](mailto:env.health@highland.gov.uk) for more information.

### **Protected Species - Halting of Work**

You are advised that work on site must stop immediately, and Scottish Natural Heritage must be contacted, if evidence of any protected species or nesting/breeding sites, not previously detected during the course of the application and provided for in this permission, are found on site. For the avoidance of doubt, it is an offence to deliberately or recklessly kill, injure or disturb protected species or to damage or destroy the breeding site of a protected species. These sites are protected even if the animal is not there at the time of discovery. Further information regarding protected species and developer responsibilities is available from SNH: [www.snh.gov.uk/protecting-scotlands-nature/protected-species](http://www.snh.gov.uk/protecting-scotlands-nature/protected-species)

### **Building Regulations**

Please note that Building Regulations and/or a Building Warrant may be applicable to some or all of the works described in this decision notice. You must check with the Council's Building Standards service prior to work commencing to establish what compliance or approval is necessary. If a warrant is required, you must not commence work until one has been applied for and issued. For more information, please contact Building Standards at [BuildingStandards@highland.gov.uk](mailto:BuildingStandards@highland.gov.uk) or on 01349 886608.

Signature:	Nicola Drummond
Designation:	Area Planning Manager – South/Major Developments
Author:	Simon Hindson / Nicola Drummond
Background Papers:	Documents referred to in report and in case file.
Relevant Plans:	Plan 1 –Location Plan Plan 2 –Site Plan Plan 3 – Plant layout Plan 4 - Elevations Plan 5 – Section Plan Plan 6 – Existing site plan

**Notes:**

- ALL DIMENSIONS IN MILLIMETRES AND ALL LEVELS IN METRES AOD UNLESS SHOWN OTHERWISE.

- SCOTTISH WATER OWNERSHIP / SITE BOUNDARY
- BOUNDARY OF SITE (APPROXIMATELY 5020m<sup>2</sup>)

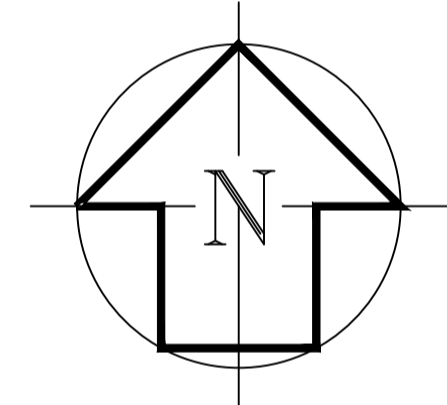
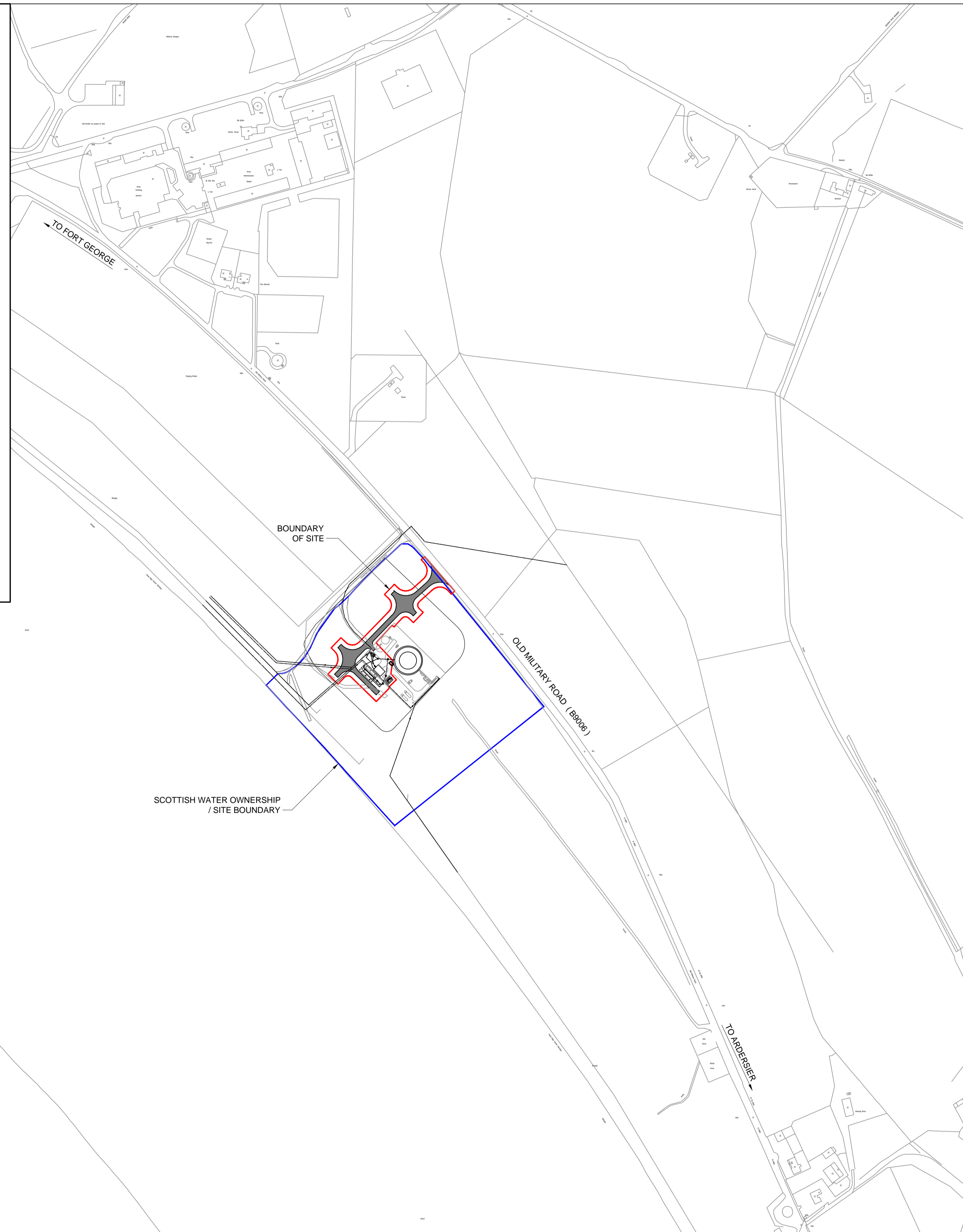
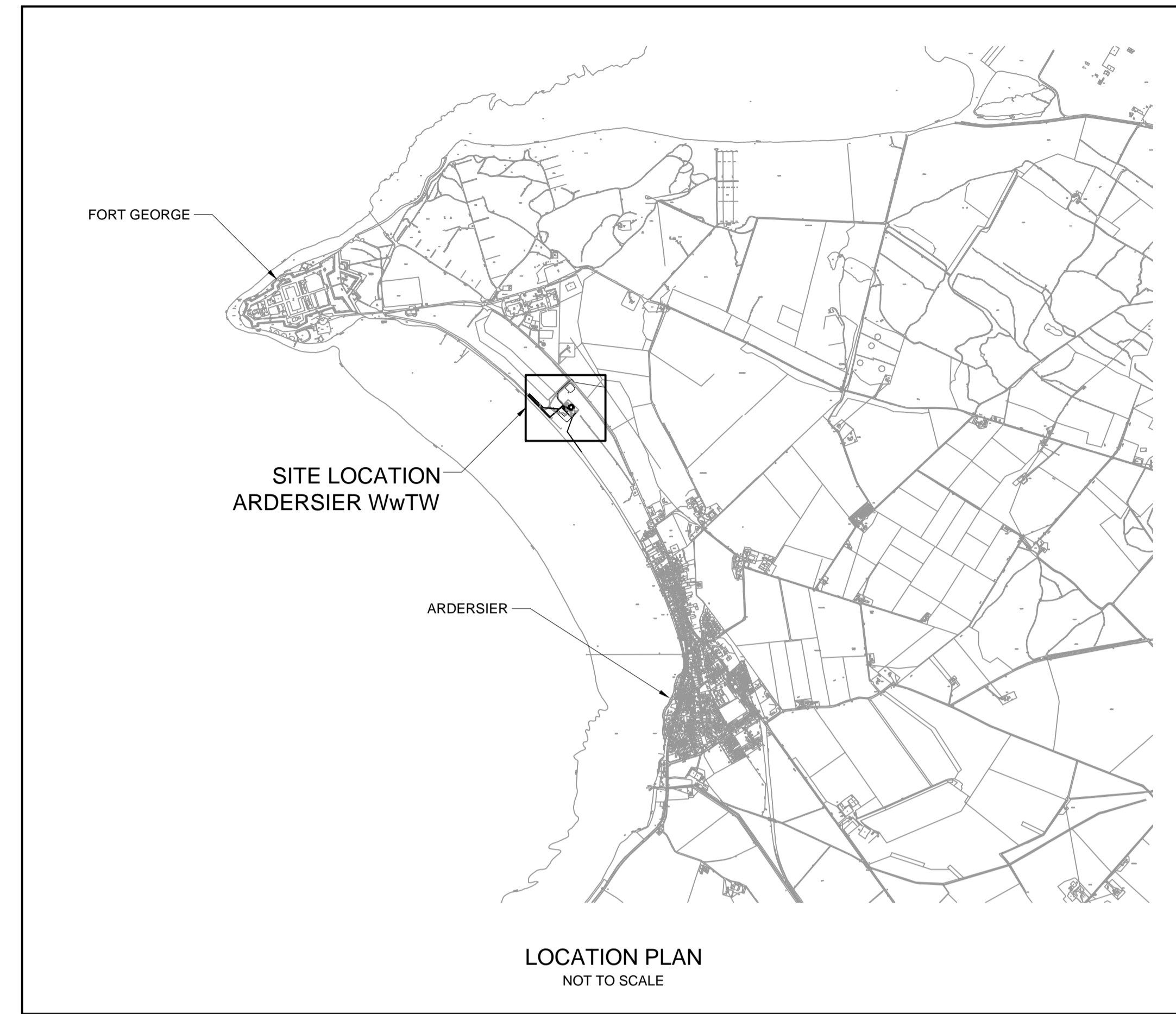

MORAY FIRTH

**SITE LOCATION**  
1:2500

0B	PLANNING ISSUE	DM	WM	GC	27/05/16
0A	DRAFT - FOR COMMENT	DM	-	-	-
Rev	Description	Drawn	Chkd.	App'd.	Date

This drawing is the property of Scottish Water and must not be copied or used for any purpose other than that for which it is supplied without the written consent of Scottish Water.

**Scottish Water**  
Always serving Scotland

SCOTTISH WATER  
CASTLE HOUSE  
6 CASTLE HOUSE  
CARNegie CAMPUS  
DUNFERMLINE  
FIFE KY11 8GG  
TEL: 01383 848200  
FAX: 01383 848371

esd  
The Bridge  
Buchanan Gate Business Park  
Cumernauld Road  
Stepps, Glasgow  
G33 6FB  
TEL 07921 491612

Originated By WMAXWELL	Drawn By DMACULLOCH	Checked By WMAXWELL	Approved By GCAMPBELL
Date 18/05/16	Date 26/05/16	Date 27/05/16	Date 27/05/16
Scale 1:2500 @ A1		Status PLANNING ISSUE	

Project Title  
**ARDESIER WwTW  
NORTH WEST  
UV PLANT OPTION**

Drawing Title  
**LOCATION PLAN**

ELLIPSE EQUIPMENT No. 005000061980  
ELLIPSE PLANT No. STW001241 | AUTOCODE No. 5000120000  
Drawing No.  
**5000061980-WW-DRA-04158001-0B**

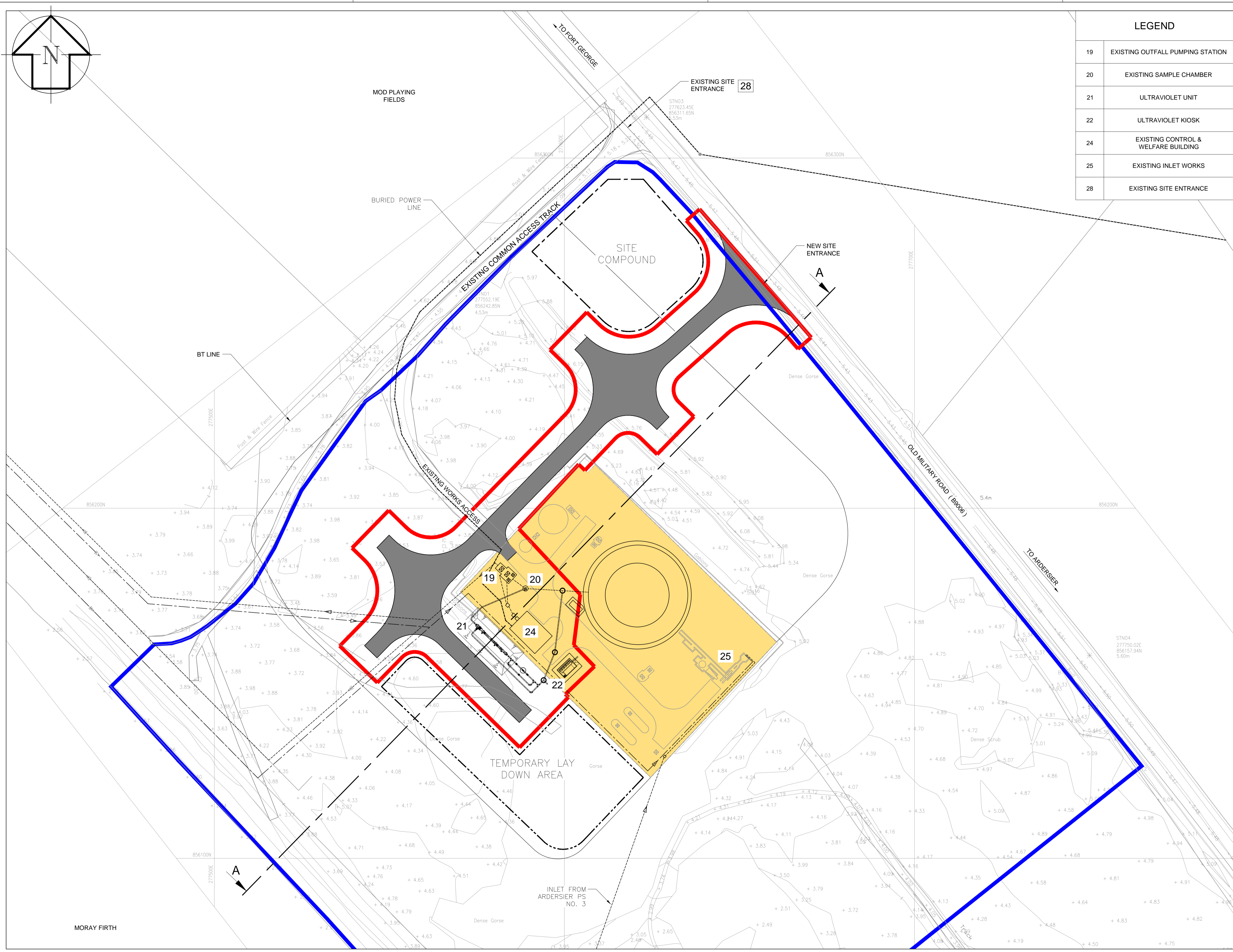
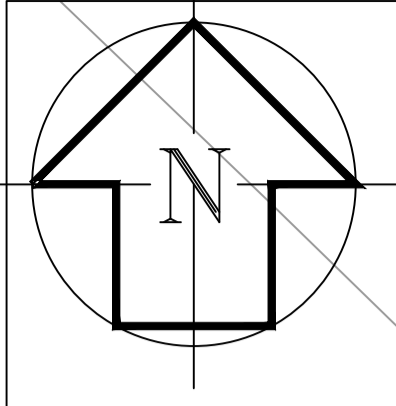

LEGEND	
19	EXISTING OUTFALL PUMPING STATION
20	EXISTING SAMPLE CHAMBER
21	ULTRAVIOLET UNIT
22	ULTRAVIOLET KIOSK
24	EXISTING CONTROL & WELFARE BUILDING
25	EXISTING INLET WORKS
28	EXISTING SITE ENTRANCE

This data is based upon the O.S. map by Scottish Water with the permission of Her Majesty's Stationery Office. © Crown Copyright. Unauthorised reproduction infringes Crown Copyright and may lead to prosecution or civil proceedings. Licence Number GD031350017

Original Size **A1**

Notes:  
1. ALL DIMENSIONS IN MILLIMETRES AND ALL LEVELS IN METRES AOD UNLESS SHOWN OTHERWISE.

- SCOTTISH WATER OWNERSHIP / SITE BOUNDARY
- BOUNDARY OF SITE (APPROXIMATELY 5020m<sup>2</sup>)
- SITE COMPOUND
- TEMPORARY LAY DOWN AREA
- EXISTING WORKS
- NEW ACCESS ROAD

OB	PLANNING ISSUE	DM	WM	GC	27/05/16
OA	DRAFT - FOR COMMENT	DM	-	-	-
Rev	Description	Drawn	Chkd.	App'd.	Date

**Scottish Water**  
Always serving Scotland

SCOTTISH WATER  
CASTLE HOUSE  
6 CASTLE HOUSE  
CARNegie CAMPUS  
DUNFERMLINE  
FIFE KY11 8GG  
TEL: 01383 848200  
FAX: 01383 848371

esd  
The Bridge  
Buchanan Gate Business Park  
Carnegie Road  
Steggs, Glasgow  
G3 6FB  
TEL 07921 491612

**esd**  
efficient service delivery

Original By WMAXWELL	Drawn By DMACULLOCH	Checked By WMAXWELL	Approved By GCAMPBELL
Date 18/05/16	Date 26/05/16	Date 27/05/16	Date 27/05/16

Scale: 1:500 @ A1  
Status: PLANNING ISSUE

Project Title  
**ARDESIER WwTW  
NORTH WEST  
UV PLANT OPTION**

Drawing Title  
**SITE LAYOUT PLAN**

ELLIPSE EQUIPMENT No. 005000061980  
ELLIPSE PLANT No. STW001241 | AUTOCODE No. 5000120000  
Drawing No. **5000061980-WW-DRA-04158002-0B**

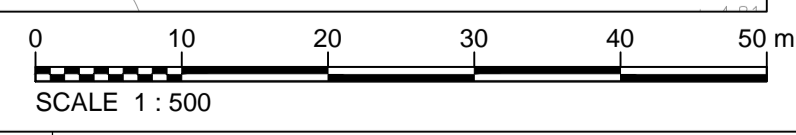

- Notes:
- ALL DIMENSIONS IN MILLIMETRES AND ALL LEVELS IN METRES AOD UNLESS SHOWN OTHERWISE.

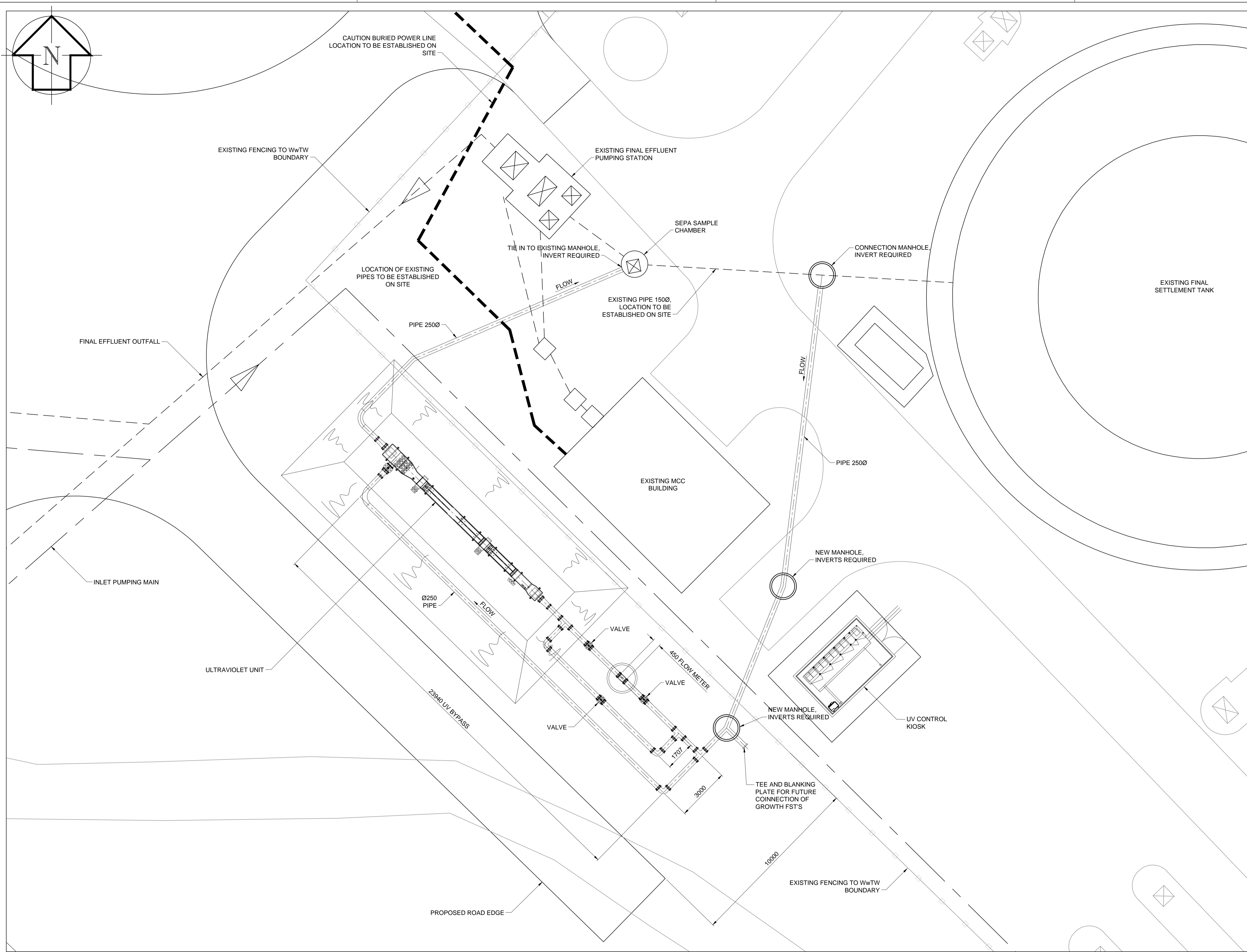

0B	PLANNING ISSUE	DM	WM	GC	27/05/16
0A	DRAFT - FOR COMMENT	DM	-	-	-
Rev	Description	Drawn	Chkd.	App'd.	Date

This drawing is the property of Scottish Water and must not be copied or used for any purpose other than that for which it is supplied without the written consent of Scottish Water.

**Scottish Water**  
Always serving Scotland

SCOTTISH WATER  
CASTLE HOUSE  
6 CASTLE HOUSE  
CARNegie CAMPUS  
DUNFERMLINE  
FIFE KY11 8GG  
TEL: 01383 848200  
FAX: 01383 848371

esd  
The Bridge  
Buchanan Gate Business Park  
Cumernauld Road  
Steggs, Glasgow  
G33 6FB  
TEL 07921 491612

**esd**  
efficient service delivery

Original By WMAXWELL	Drawn By DMACULLOCH	Checked By WMAXWELL	Approved By GCAMPBELL
Date 18/05/16	Date 26/05/16	Date 27/05/16	Date 27/05/16
Scale 1:100 @ A1	Status PLANNING ISSUE		

Project Title  
**ARDESIER WwTW  
NORTH WEST  
UV PLANT OPTION**

Drawing Title  
**UV PLANT LAYOUT**

ELLIPSE EQUIPMENT No. 005000061980  
ELLIPSE PLANT No. STW001241 | AUTOCODE No. 5000120000  
Drawing No.  
**5000061980-WW-DRA-04158003-0B**

Notes:

1. ALL DIMENSIONS IN MILLIMETRES AND ALL LEVELS IN METRES AOD UNLESS SHOWN OTHERWISE.

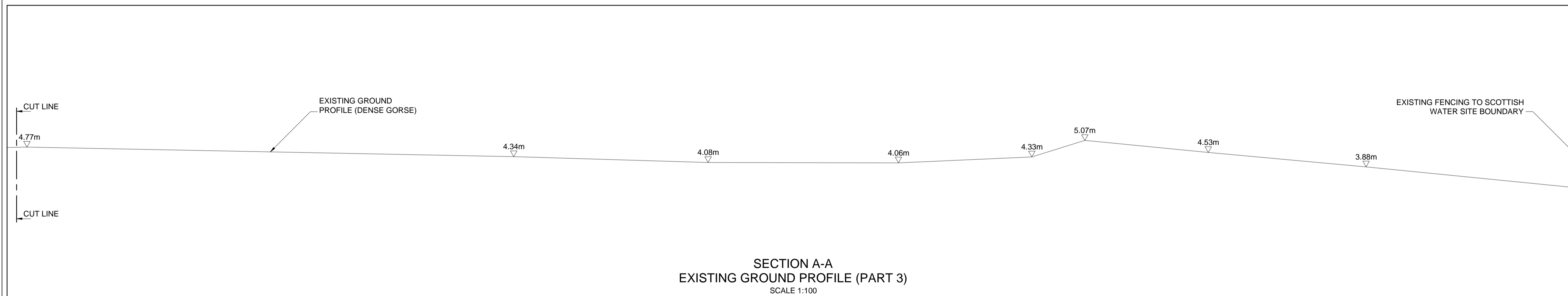
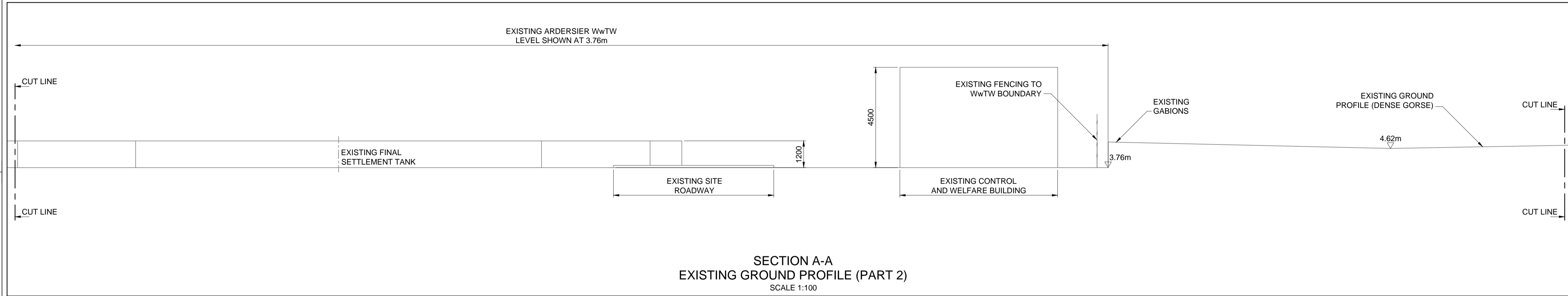
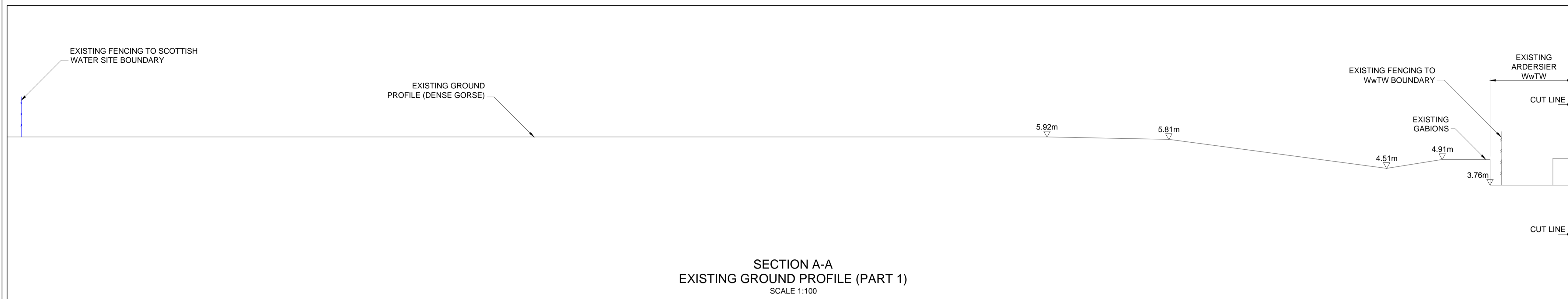

0B	PLANNING ISSUE	DM	WM	GC	27/05/16
0A	DRAFT - FOR COMMENT	DM	-	-	-
Rev	Description	Drawn	Chkd.	App'd.	Date

This drawing is the property of Scottish Water and must not be copied or used for any purpose other than that for which it is supplied without the written consent of Scottish Water.

**Scottish Water**  
Always serving Scotland

SCOTTISH WATER  
CASTLE HOUSE  
6 CASTLE HOUSE  
CARNegie CAMPUS  
DUNFERMLINE  
FIFE KY11 8GG  
TEL: 01383 848200  
FAX: 01383 848371

esd  
The Bridge  
Buchanan Gate Business Park  
Cumnor Road  
Steggs, Glasgow  
G3 6FB  
TEL 07921 491612

**esd**  
efficient service delivery

Originated By WMAXWELL	Drawn By DMACULLOCH	Checked By WMAXWELL	Approved By GCAMPBELL
Date 18/05/16	Date 26/05/16	Date 27/05/16	Date 27/05/16
Scale 1:100 @ A1		Status PLANNING ISSUE	

Project Title  
**ARDESIER WwTW  
NORTH WEST  
UV PLANT OPTION**

Drawing Title  
**SECTION A-A  
EXISTING**

ELLIPSE EQUIPMENT No.	005000061980
ELLIPSE PLANT No.	STW001241
AUTOCODE No.	5000120000
Drawing No.	<b>5000061980-WW-DRA-04158004-0B</b>

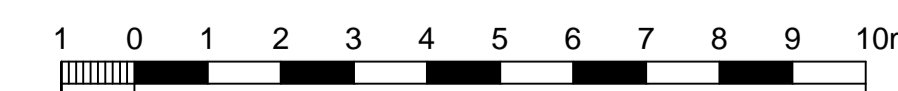

Notes:  
1. ALL DIMENSIONS IN MILLIMETRES AND ALL LEVELS IN METRES AOD UNLESS SHOWN OTHERWISE.

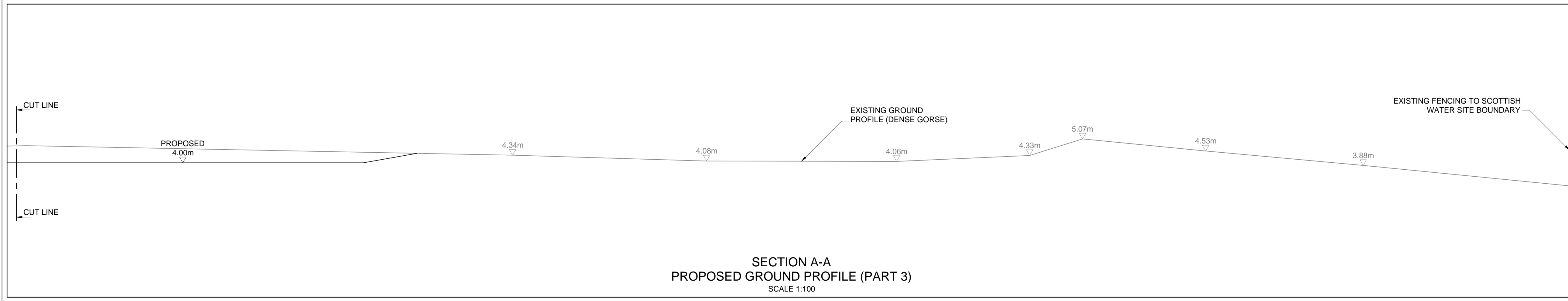
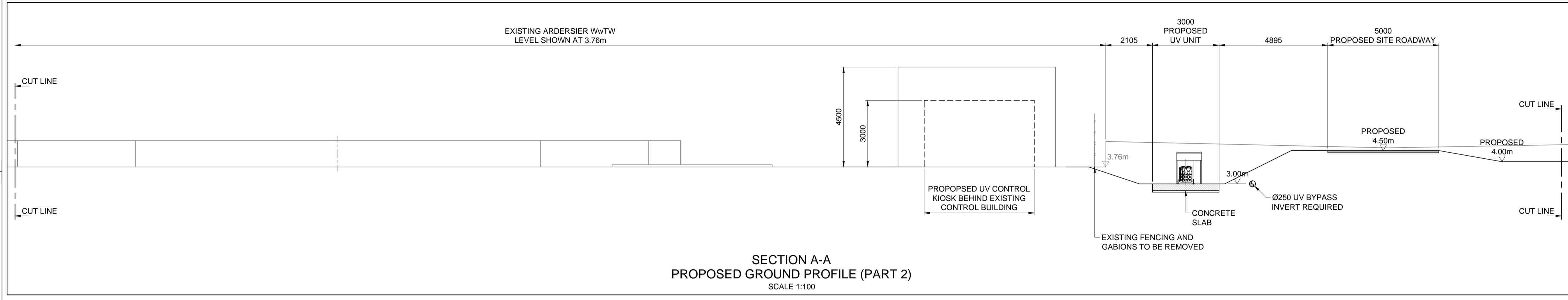
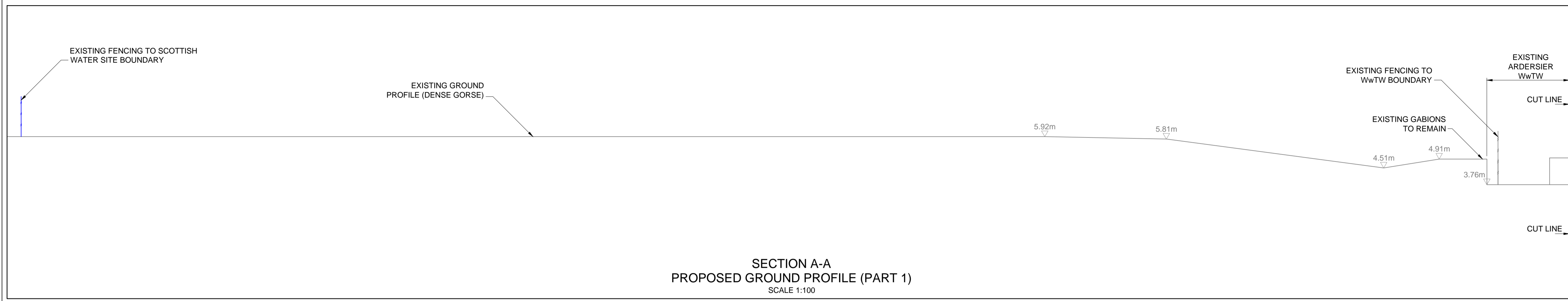

0B	PLANNING ISSUE	DM	WM	GC	27/05/16
0A	DRAFT - FOR COMMENT	DM	-	-	-
Rev	Description	Drawn	Chkd.	App'd.	Date

This drawing is the property of Scottish Water and must not be copied or used for any purpose other than that for which it is supplied without the written consent of Scottish Water.

**Scottish Water**  
Always serving Scotland

SCOTTISH WATER  
CASTLE HOUSE  
6 CASTLE HOUSE  
CARNegie CAMPUS  
DUNFERMLINE  
FIFE KY11 8GG  
TEL: 01383 848200  
FAX: 01383 848371

esd  
The Bridge  
Buchanan Gate Business Park  
Cumnor Road  
Steggs, Glasgow  
G33 6FB  
TEL 07921 491612

**esd**  
efficient service delivery

Originated By WMAXWELL	Drawn By DMACULLOCH	Checked By WMAXWELL	Approved By GCAMPBELL
Date 18/05/16	Date 26/05/16	Date 27/05/16	Date 27/05/16

Scale: 1:100 @ A1  
Status: PLANNING ISSUE

Project Title  
ARDESIER WWTW  
NORTH WEST  
UV PLANT OPTION

Drawing Title  
SECTION A-A  
PROPOSED

ELLIPSE EQUIPMENT No. 005000061980  
ELLIPSE PLANT No. STW001241 | AUTOCODE No. 5000120000

Drawing No.  
**5000061980-WW-DRA-04158005-0B**

**Notes:**

1. ALL DIMENSIONS IN MILLIMETRES AND ALL LEVELS IN METRES AOD UNLESS SHOWN OTHERWISE.
2. COLOUR - IVY GREEN 9BS 12 C 39)

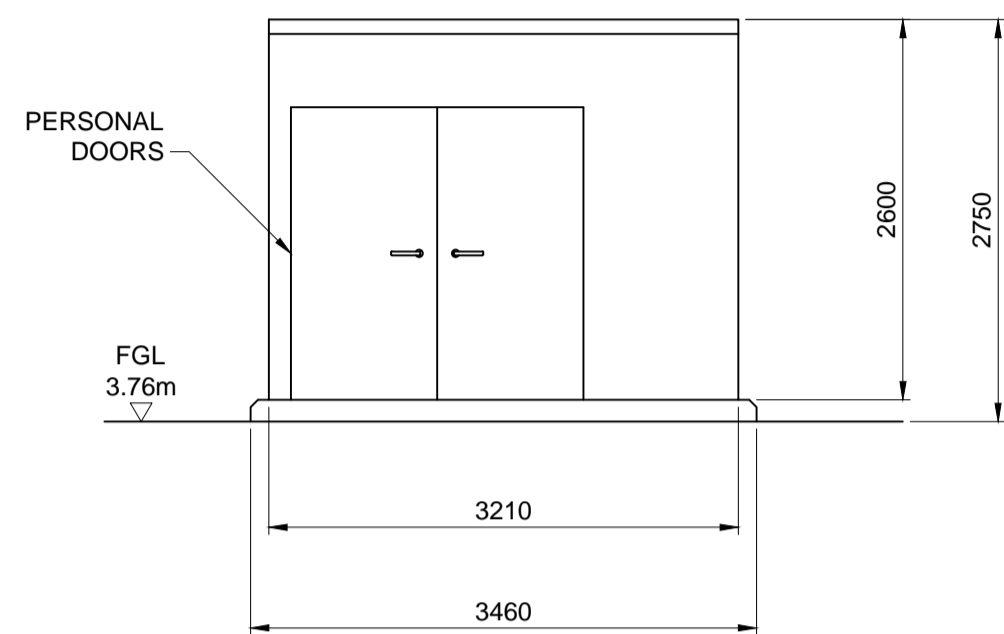

**VIEW ON A**  
SCALE 1:50

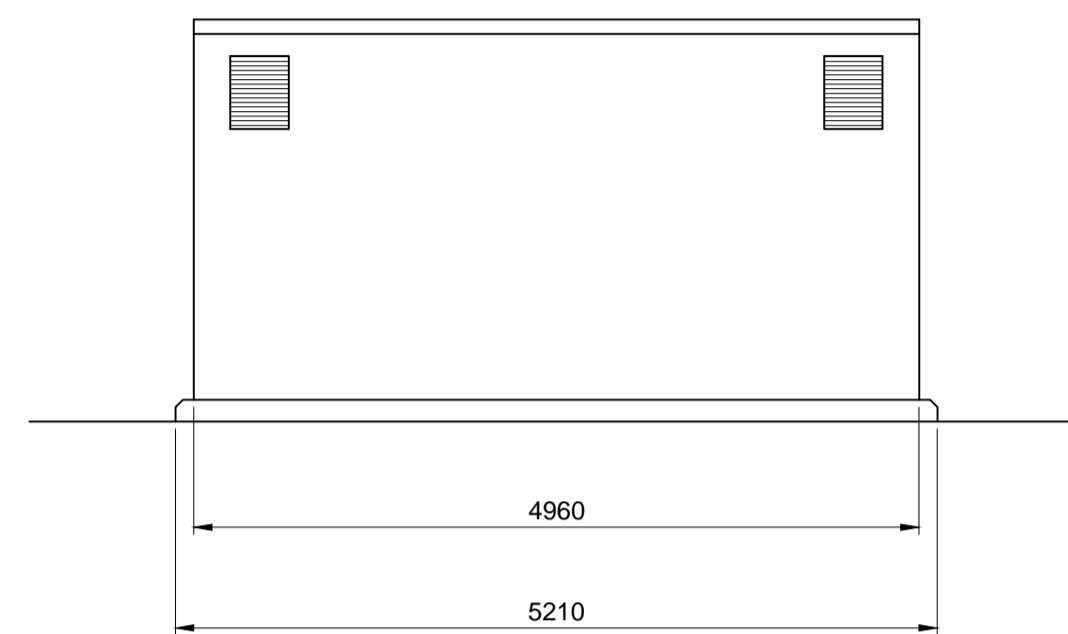

**VIEW ON B**  
SCALE 1:50

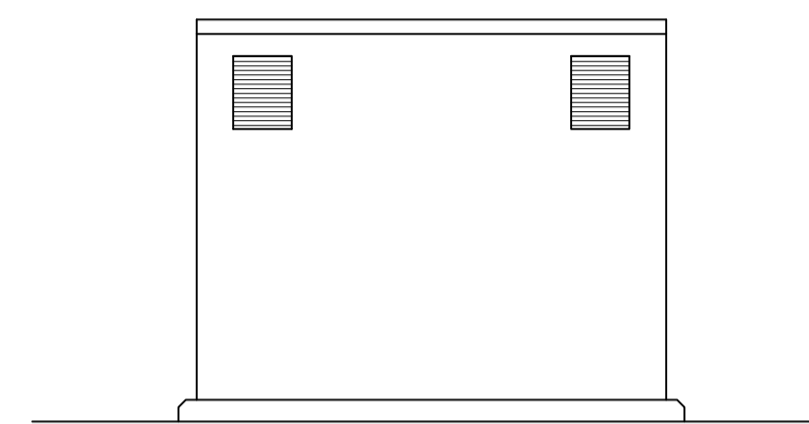

**VIEW ON C**  
SCALE 1:50

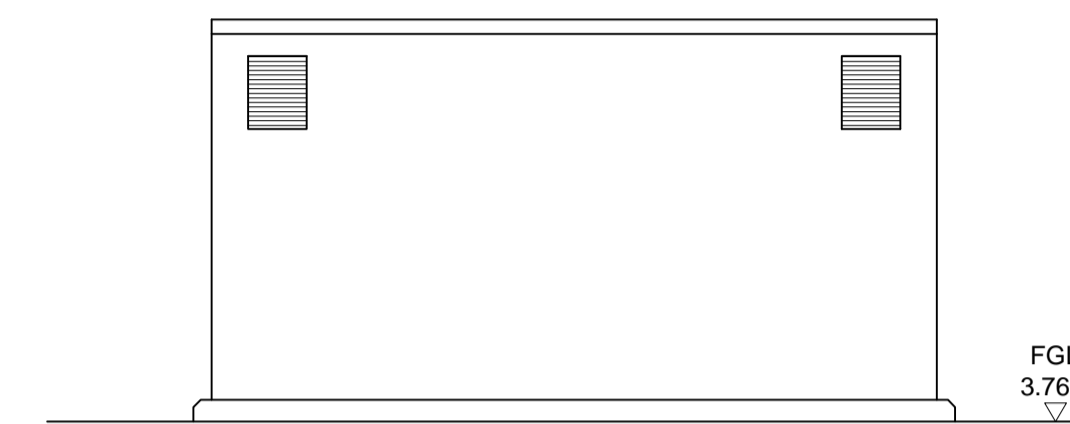

**VIEW ON D**  
SCALE 1:50

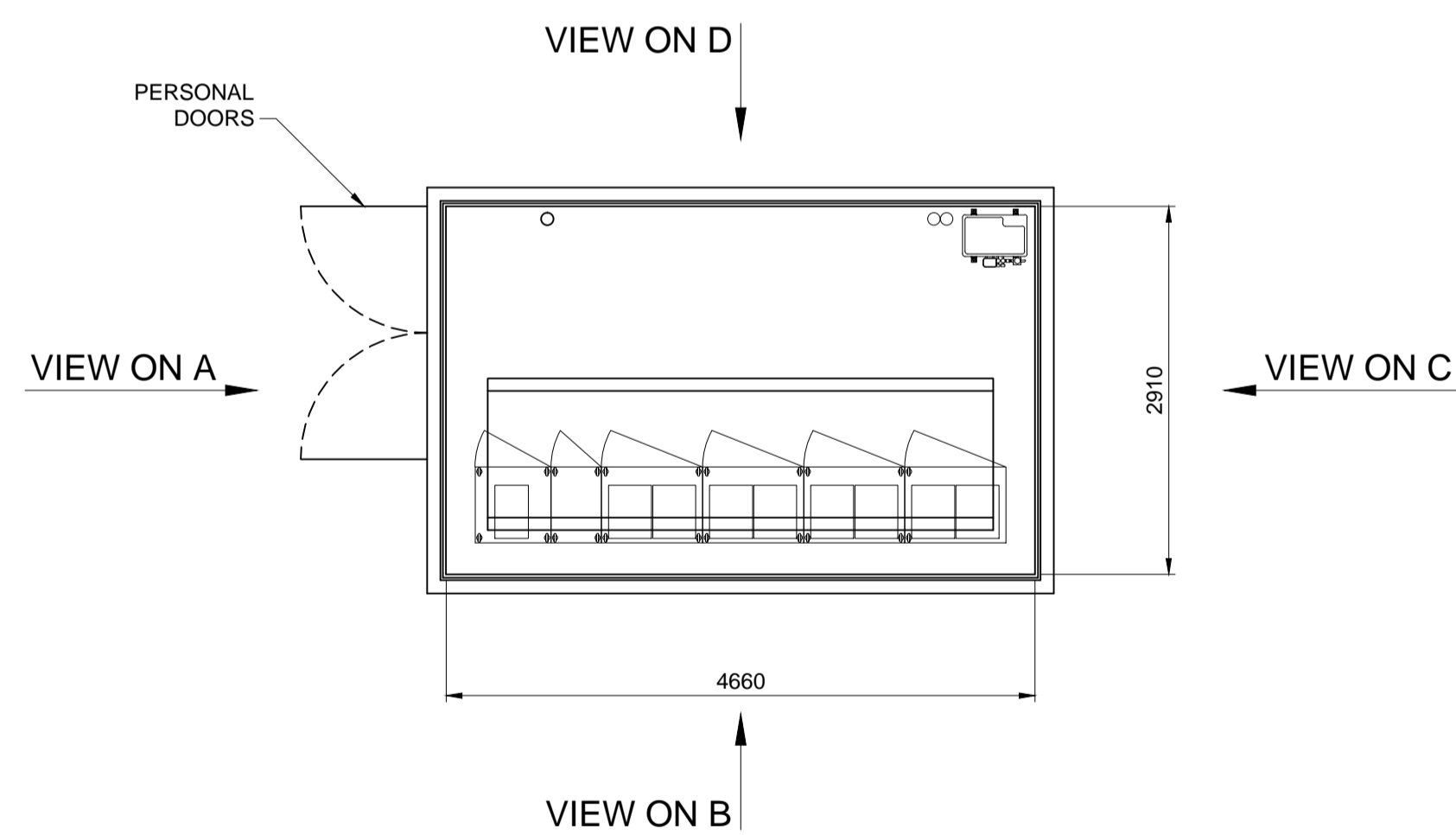

**PLAN OF UV CONTROL KIOSK**  
SCALE 1:50

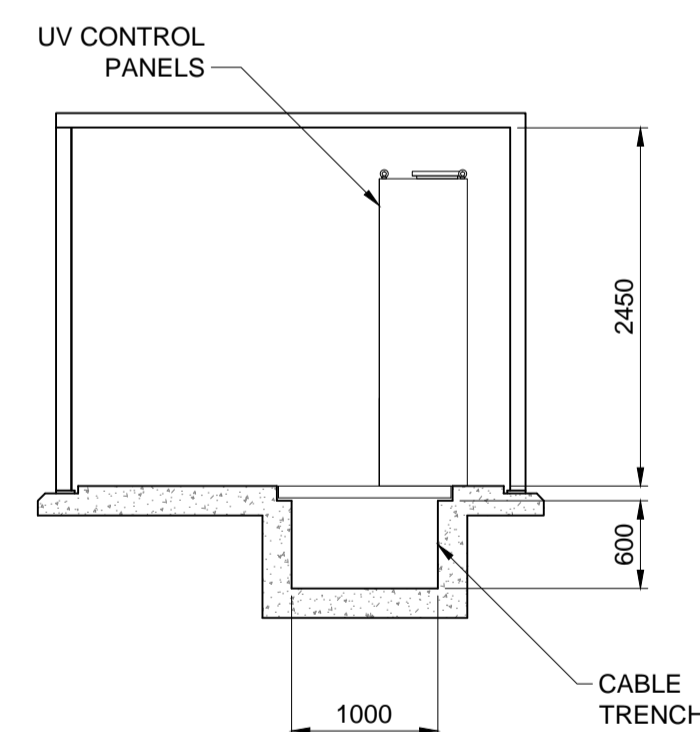

**TYPICAL SECTION THROUGH UV CONTROL KIOSK**  
SCALE 1:50

0B	PLANNING ISSUE	DM	WM	GC	27/05/16
0A	DRAFT - FOR COMMENT	DM	-	-	-
Rev	Description	Drawn	Chkd.	App'd.	Date

This drawing is the property of Scottish Water and must not be copied or used for any purpose other than that for which it is supplied without the written consent of Scottish Water.

**Scottish Water**  
Always serving Scotland

SCOTTISH WATER  
CASTLE HOUSE  
6 CASTLE HOUSE  
CARNegie CAMPUS  
DUNFERMLINE  
FIFE KY11 8GG  
TEL: 01383 848200  
FAX: 01383 848371

esd  
The Bridge  
Buchanan Gate Business Park  
Cumbernauld Road  
Stepps, Glasgow  
G33 6FB  
TEL 07921 491612

**esd**  
efficient service delivery

Originated By WMAXWELL	Drawn By DMACULLOCH	Checked By WMAXWELL	Approved By GCAMPBELL
Date 18/05/16	Date 26/05/16	Date 27/05/16	Date 27/05/16
Scale 1:50 @ A1		Status PLANNING ISSUE	

Project Title  
**ARDESIER WwTW  
NORTH WEST  
UV PLANT OPTION**

Drawing Title  
**UV CONTROL KIOSK**

ELLIPSE EQUIPMENT No. 005000061980  
ELLIPSE PLANT No. STW001241 | AUTOCODE No. 5000120000  
Drawing No.  
**5000061980-WW-DRA-04158006-0B**

