

Agenda Item	8
Report No	G/4/23

THE HIGHLAND COUNCIL

Committee: Gaelic Committee

Date: 30 March 2023

Report Title: Gaelic Medium Education and Gaelic Learner Education – The Highland Council

Report By: Executive Chief Officer Performance and Governance

1. Purpose/Executive Summary

1.1 This Report informs Members of

- a) An outline of the current key priorities within Gaelic Education (GLP3) with a specific focus on the following themes;
- Gaelic Medium Education – Early Years, Primary and Secondary
 - Gaelic Learner Education – Primary and Broad General Education Phase Secondary Education
 - Gaelic Language Plan Strategic Priorities for Gaelic Education
- b) An update on the creation of catchment for Gaelic Medium provisions and Gaelic Medium Schools.

2. Recommendations

2.1 Members are asked to:

- i. Consider the report and note the revised draft Strategic Priorities for Gaelic Education for The Highland Council's fourth Gaelic Language Plan
- ii. Note the areas of current and future development to support Gaelic teacher recruitment and sustainability; and
- iii. Consider the current position on the Applecross Gaelic Medium Primary Education request.

3. Implications

- 3.1 Resource -The resource implications are within the current main budget stream which include Gaelic Specific Grant, Bòrd na Gàidhlig, and Gaelic Language Act Implementation Fund (Bòrd na Gàidhlig) alongside core Council revenue funding.
- 3.2 Legal - The Highland Council has a requirement to implement its Gaelic Language Plan under the Gaelic Language (Scotland) Act of 2005.
- 3.3 Community (Equality, Poverty, Rural and Island), Climate Change / Carbon Clever, Risk – there are no specific risks arising as a consequence of this report.
- 3.6 Gaelic - The report enhances Gaelic development within The Highland Council area and supports the implementation of the Gaelic Language Plan.

4 Gaelic Education within the framework of the Gaelic Language Plan

- 4.1 The Highland Council has a clear focus on increasing Gaelic usage and to increase the number of Gaelic speakers. The Council continues to be committed to providing and enhancing Gaelic Medium and Gaelic Education; recognising this as one of the key drivers in sustaining and developing Gaelic.
- 4.2 The Highland Council's fourth Gaelic Language Plan is prepared within the framework of the Gaelic Language (Scotland) Act 2005. The draft Gaelic Language Plan spans a five-year period from 2023 to 2028 and builds on the progress made in the previous plan.
- 4.3 Bòrd na Gàidhlig and The Highland Council have worked together to produce a set of Strategic Priorities for the development of Education within the Plan to further grow the use of Gaelic and the learning of Gaelic in schools.

Draft Strategic Priorities – Gaelic Education

- 4.1 Deliver continued promotion and growth in GME and GLE at all levels including delivery of Gaelic as a modern language, with 70% of primary schools providing Gaelic as an L2 and L3 to increase the provision of Gaelic across the authority.
- 4.2 Expand the delivery of Gaelic Medium Education with increased secondary subject delivery, creation of new standalone schools and new early-years, primary and secondary provision.

The Gaelic Team will continue to liaise on these Strategic Priorities which are currently going through approval at a future Bòrd na Gàidhlig Committee.

Expanded actions to support the priorities can be found in the draft [GLP4](#).

5. Strategic Priority 4.1

5.1 4.1 Desired Outcomes

Highland will expand and support the delivery of Gaelic as a modern language in line with the 1+2 initiative. A targeted support model of professional learning and teaching support will be delivered for identified schools to increase provision of L2 and L3 Gaelic.

The Highland Council will create a rationale for GME and GLE delivery. The Highland Council will develop and incorporate a strategic vision to provide guidance regarding

Gaelic curriculum offers across Highland, maximising the use of digital and technology opportunities available.

During internal working groups, the following data was gathered on schools that have delivered Gaelic as L2 and L3 across Highland.

The following table illustrates that a high percentage Primary Schools in the West are providing a Gaelic education pathway. A strategic support programme with a key focus on the other areas of Highland is now under consideration to help schools provide continued growth in Gaelic education opportunities.

Area	L2	L3	Other	Total number of primary schools	Provision of L2 and L3 as a percentage within the area
Mid	1	9	23	33	30%
North	2	7	21	30	30%
South	0	24	26	50	48%
West	24	23	7	54	87%

The primary draft action to contribute to achievement of this priority is included in GLP4. Targeted schools will include for example where Gaelic and English medium provision are situated together in the same school.

The Gaelic Team will collaborate and support opportunities for the pupils in English medium to learn about Gaelic language and culture as part of Scotland's identity. This is also advised in the Statutory Advice on Gaelic Education.

5.2 Strategic Priority 4.2 4.2 Desired Outcomes

The Highland Council will complete a feasibility study on 3–18 Gaelic Education for Inverness, to ensure a strategic vision of the future development and sustainability of Gaelic education across Highland.

The Highland Council will audit and review Gaelic status designations for schools. We will review current delivery models of GME across Highland and investigate potential new delivery models and structures, including increased 3–18 provision.

6. Gaelic Medium Education – Catchment update

6.1 At the time of writing, the Council has created Gàidhlig Medium catchment areas for 16 of the 20 primary schools in Highland that offer GME.

Since the last time this was reported to the Committee, catchment areas have been approved for Glenurquhart PS and Glenurquhart High School, and for Plockton PS, Lochcarron PS and Plockton High School.

6.2 Remaining GM catchments

Officials have held initial discussions with Bòrd na Gàidhlig and Comann nam Pàrant, about formal consultations for the remaining four GM primary catchments in Highland, that have not yet been created or proposed. These relate to the Bun-sgoil Ghàidhlig Inbhir Nis, Millbank Primary School, Dingwall Primary School, and Craighill Primary School/new Tain Campus.

Further informal consultation, with local Elected Members and with parents, is required before a formal Proposal can be put to Committee.

It is likely that a single Proposal Paper will be put forward for Bun-sgoil Ghàidhlig Inbhir Nis, Millbank Primary School, and Dingwall Primary School, as any changes to the proposed GM catchments for one of these would affect the other. The proposals will also address GM catchments for the associated secondary schools. The proposal will therefore be a complex one.

7. Gaelic Medium Education Teacher Recruitment update

- 7.1 Officers in Education and the Gaelic Team continue to work closely with Sabhal Mòr Ostaig to mitigate against GME teacher recruitment pressures across Highland as well as provide sustainability across our Gaelic provisions.

The following information was provided by Sabhal Mòr Ostaig on projected teacher numbers.

Student numbers:

- BA Gaelic agus Education
Primary: 15 (9 graduating this year)
Secondary: 2 (one student graduating this year)
Applications for year 1 (2023-24) look healthy
- PGDE (Primary): 7 students graduating this year
- PGDE (Secondary): 1 student graduating this year (History)

MEd in Gaelic Education: 9 teachers on the programme

BA and PGDE Sponsorship (Gaelic pathway): Six students have opted for sponsorship from Highland Council this year and will complete their TIS year in the council area.

Pathway to Teaching: SMO received Bòrd na Gàidhlig funding to run a week-long pilot course with local pupils in Skye in September 2023 to encourage interest in Gaelic teaching at Senior Phase in schools. The pupils will complete the course on the SMO campus and local schools. If the course is successful, we would hope to roll it out to pupils in other areas in subsequent years

8 Gaelic Medium Primary Education (GMPE) request – Applecross Primary

- 8.1 Highland Council met with parents of Applecross Primary school on 2 March to discuss their GMPE request. The Highland Council's assessment response can be read [here](#).

At this point, a decision has been made not to secure Gaelic Medium Education at Applecross Primary.

This position is based on an accommodation review. The suitability and internal constraints of the building determine that there is no space for an additional GME classroom. Site constraints have impacted the outcome as we cannot extend or install modular accommodation at this site. Applecross PS has three rooms. B/0/009 is used as a classroom for P1-7 pupils. B/0/008 is a multi-purpose room that is used for dining, general purpose pupil use, library, Head Teacher office space as well as additional support needs. While this room is big enough to be used as a classroom, an impact assessment determines this would not be suitable as it would increase suitability issues at the school in regards infrastructure. The school would lose the current functions of the space such as dining, ASN and office space which are required. B/0/007 is used as a nursery for an early years class. The nursery requires full access to this room for their registration. These three rooms are required to retain their current uses and to allow the school to function. Therefore, there is no space within the building to accommodate an additional primary classroom.

Parents have been advised that access to Gaelic Medium Education at Lochcarron would be a consideration, if this request was made.

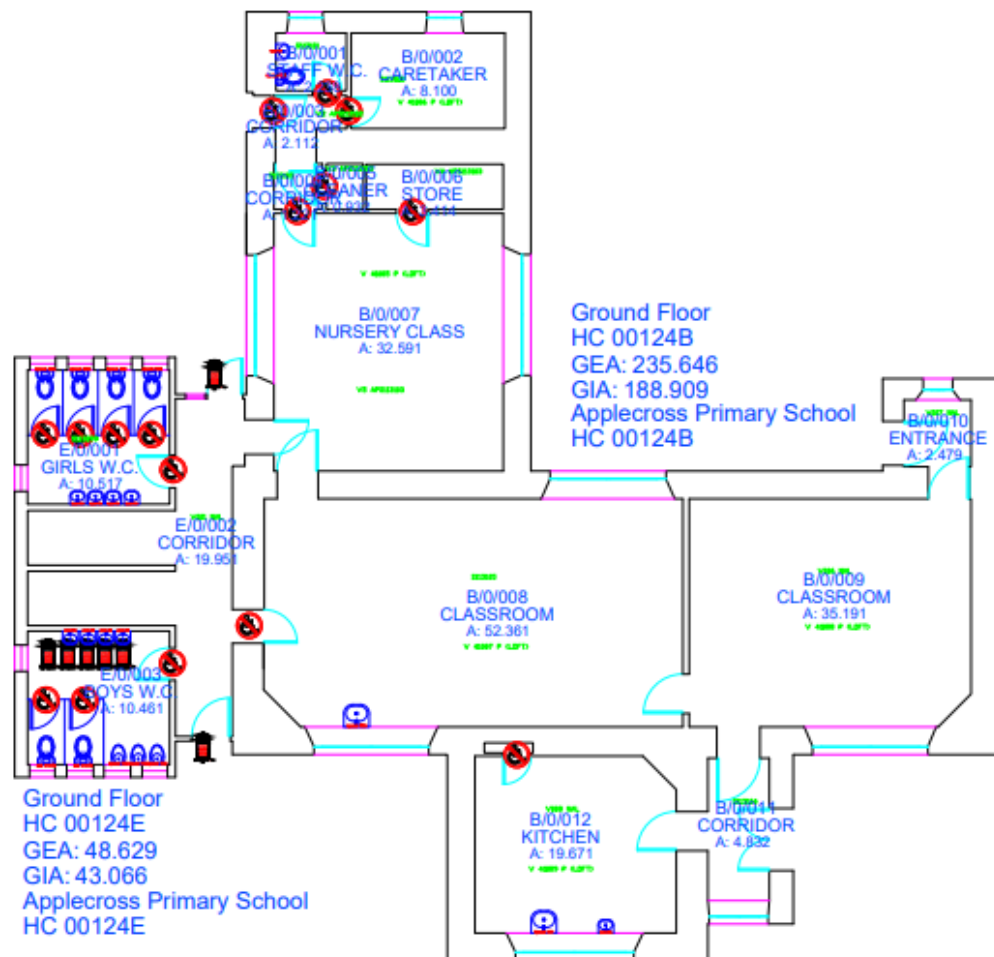

Designation: ECO Performance and Governance,

Date:28/02/23

Author: Lena Walker, Gaelic Development Manager

